

FABRICATED STEEL SLIDE GATES

The design and finishing of Fabricated Slide Gates manufactured by **hydrostec** assure a wide scope of application to this classical closing equipment in hydraulic projects of sewage treatment plants and irrigation systems successfully replacing the AWWA Standard cast iron Wall Gates. The standard line of Slide Gates covers a wide range of dimensions, as shown in the table below, and they are dimensioned for a hydraulic load of 5 mca (0,5 bar).

Greater or different sizes and hydraulic pressures over 5 mca are also supplied, according to the standardized designs.

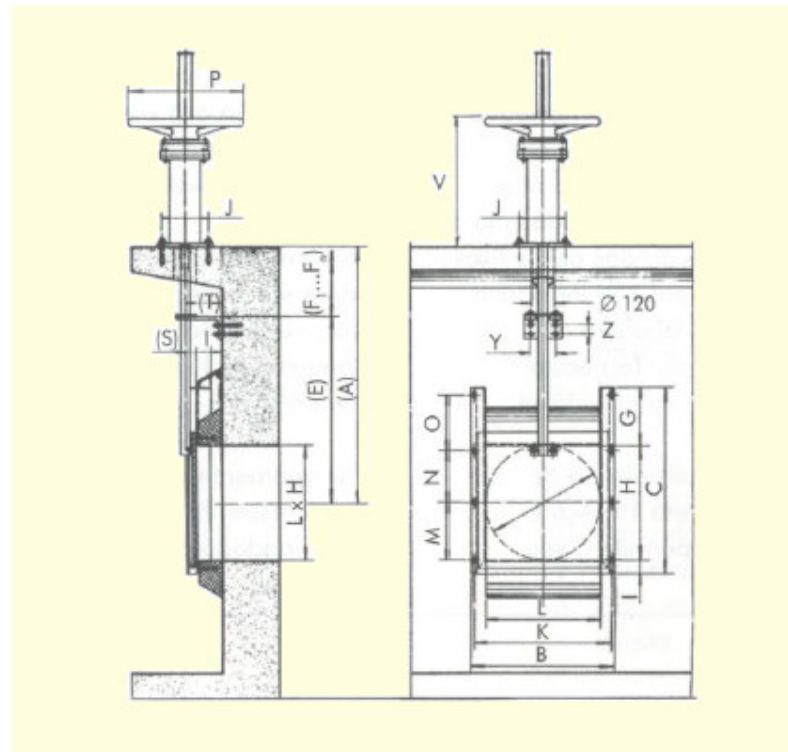

Dimensions in mm

DN	L x H	B	C	G	I	K	M	N	O	J	P	V	Y	Z
200	200 X 200	300	400	200	65	300	140	105	105	210	500	800	100	40
300	300 X 300	430	600	300	65	400	190	180	180	210	500	800	100	40
400	400 X 400	530	800	400	65	500	240	255	255	210	500	800	100	40
500	500 X 500	630	1000	500	65	600	290	330	330	210	500	800	100	40
600	600 X 600	730	1200	600	65	700	340	405	405	210	500	800	100	40
700	700 X 700	830	1300	600	65	800	390	430	430	210	500	800	100	40
800	800 X 800	930	1400	600	65	900	440	455	455	210	500	800	100	40
900	900 X 900	1030	1700	700	65	1000	490	580	580	210	600	800	100	40
1000	1000 X 1000	1130	1800	800	65	1100	540	605	605	210	600	800	100	40
1100	1100 X 1100	1230	1900	800	65	1200	590	630	630	210	600	800	100	40
1200	1200 X 1200	1330	2000	800	65	1300	640	655	655	210	600	800	100	40
1300	1300 x 1300	1630	2200	900	65	1400	690	730	730	210	600	800	100	40
1400	1400 x 1400	1730	2400	1000	65	1500	740	805	805	210	600	800	100	40
1500	1500 x 1500	2630	2500	1000	65	1600	790	830	830	210	600	800	100	40

- The dimensions A; E; F1 Fn; S; T represent constructive dimensions defined for each design.
- The dimensions F1 Fn represent the distance among Stem guides from the lower Stem guide.

Construction

The Slide Gates are welded assemblies of steel plate (ASTM A36). The embedded parts, in case of application in sewage and water treatment systems are fully welded assemblies of stainless steel (AISI 304). For irrigation systems applications, unless otherwise specified, only the sealing faces of the embedded parts are welded assemblies of stainless steel. Upon request the gate leaf may be also supplied in stainless steel construction.

The overall Slide Gate line is manufactured to allow its application with double flow

direction and, consequently, to assure the water tightness in both pressure directions.

The gate driving is accomplished by manual actuators, with no reduction, with threaded stems (trapezoidal thread). Upon request the stem may be supplied in stainless steel.

Upon request the gates may be supplied with electrical actuators or hydraulic and pneumatic drivers.

The gates, if specified, may be operated by remote control or supplied with an automatic control and regulated opening.

Installations

The Slide Gates construction allows a great flexibility for installation. The three figures below represent the most typical situations.

The dimensions supplied (in millimeters) are only as a guide.

In order to prevent the stem (s) buckling, stem guide bearings are provided; their number and location are defined according to each project case in function of the maximum distance between the gate top and the operating floor and of the required maximum gate closing force.

