

D60.34.0-I

PIPES

Fluid transports

On request, we supply a complete line of welded steel pipes and special parts of conduits and penstocks. For Pumping Stations, Aqueducts, Irrigation, Water Distribution and Sewage Systems.

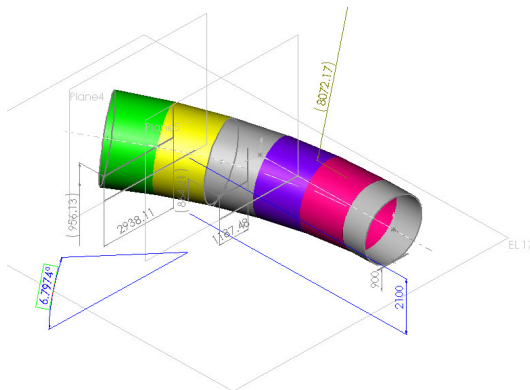

The pipes and pipe accessories design and manufacturing may be in compliance with the following standards:

- ABNT
- ASTM
- ASME
- AWWA
- DIN
- AFNOR

and others as requested by the customer. All welding processes and the welders are pre-qualified in compliance with "ASME Pressure Vessel Code".



The supply of this equipment, made conforming to international standards, is of the highest quality.

The special pipes parts and accessories manufactured by **hydrostec** are:

- Curves and elbows,
- Branches,
- Concentric and eccentric cones,
- Special parts such as Crossheads, T's pieces and others,
- Joints (couplings) as dilatation or assembly parts normalized or designed upon request,
- Supporting saddles: fixed or movable type,
- Manhole, flanges and others.

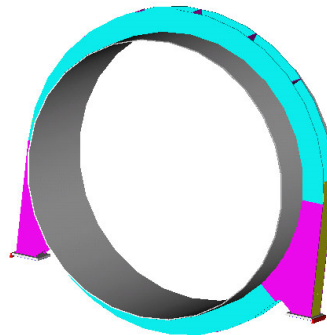

Alongside to the equipment supply, **hydrostec** may provide the project with complete hydraulic and mechanical dimensioning, as well as perform the penstock site assembly.

The coating and the type of anticorrosive protection for pipes and accessories should be according to the customer's specifications.

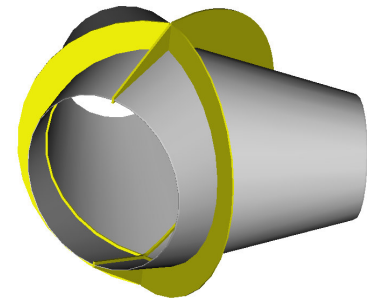

DRESSER 38 type joint

DN mm	Pipe outside \varnothing mm	\varnothing A mm	L mm	Weight Kgf
250	273	381	178	15
300	323,9	432	230	26
350	355,6	464	230	38
400	406,4	514	245	44
450	457,2	565	245	48
500	508	616	245	53
550	558,8	667	245	58
600	609,6	718	245	63
650	660,4	768	245	68
700	711,2	820	245	74
750	762	895	252	104
800	812,9	946	252	110
850	883,6	997	252	117
900	914,4	1048	252	124
950	965,2	1098	252	132
1000	1016	1150	326	158
1050	1066,8	1200	326	165
1100	1117,6	1251	326	172
1150	1168,4	1302	326	180
1200	1219,2	1352	326	188
1250	1270	1403	326	196
1300	1320,8	1454	326	204
1350	1371,6	1505	326	212
1400	1422,4	1556	326	220
1450	1473,2	1607	326	230
1500	1524	1657	326	241
1550	1574,8	1708	326	252
1600	1625,6	1760	326	264
1650	1676,4	1810	326	275
1700	1727,2	1860	326	288
1750	1778	1911	332	302
1800	1828,8	1961	332	314
1850	1879,6	2013	332	328
1900	1930,4	2064	332	342
1950	1981,2	2115	332	353
2000	2032	2165	332	363
2050	2082,8	2216	332	374
2100	2133,6	2267	332	385
2200	2235,2	2369	332	397
2300	2336,8	2470	332	410
2400	2438,4	2572	332	425
2500	2540	2673	332	440

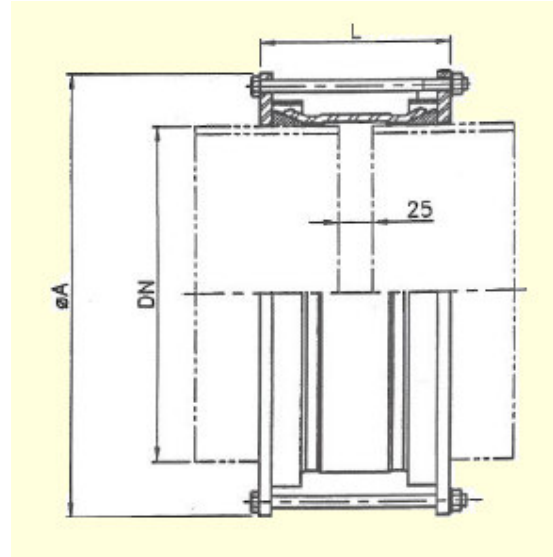

Materials

- body and flanges : ASTM A36
- screws and bolts : SAE 1020 galvanized
- sealing gasket : SBR
- finishing : according to AWWA
- pressure class : PN10-PN16-PN25

Pieces for special conditions available on request.

DRESSER 38 type joints with harness and stud bolts

DN mm	Pipe outside \varnothing mm	\varnothing A mm	LT mm	L mm	Weight Kgf
250	273	527	660	925	79
300	323,9	578	660	925	107
350	355,6	610	660	1025	129
400	406,4	660	660	1025	147
450	457,2	738	710	1025	165
500	508	788	710	1125	180
550	558,8	839	710	1125	200
600	609,6	890	710	1125	220
650	660,4	940	710	1125	252
700	711,2	991	710	1125	270
750	762	1042	760	1125	330
800	812,9	1093	760	1125	348
850	863,6	1144	760	1225	388
900	914,4	1206	860	1225	414
950	965,2	1257	860	1225	435
1000	1016	1308	860	1225	476
1050	1066,8	1358	860	1225	507
1100	1117,6	1409	860	1525	607
1150	1168,4	1460	860	1525	633
1200	1219,2	1512	960	1525	689
1250	1270	1562	960	1525	702
1300	1320,8	1613	960	1525	741
1350	1371,6	1664	1040	1525	788
1400	1422,4	1714	1040	1525	814
1450	1473,2	1766	1040	1525	842
1500	1524	1830	1070	1625	928
1550	1574,8	1880	1070	1625	958
1600	1625,6	1930	1070	1625	989
1650	1676,4	1982	1120	1625	1036
1700	1727,2	2032	1120	1625	1068
1750	1778	2083	1120	1625	1102
1800	1828,8	2146	1145	1825	1308
1850	1879,6	2198	1145	1825	1343
1900	1930,4	2248	1145	1825	1379
1950	1981,2	2300	1145	1825	1410
2000	2032	2350	1145	1825	1443
2050	2082,8	2400	1145	1825	1475
2100	2133,6	2464	1145	1925	1595
2200	2235,2	2565	1145	1925	1653
2300	2336,8	2666	1145	1925	1711
2400	2438,4	2768	1220	2025	1840
2500	2540	2870	1220	2025	1904

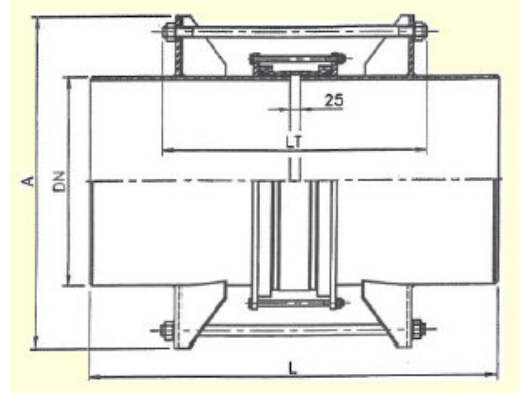

Materials

- body and flanges : ASTM A36
- screws and bolts : SAE 1020 galvanized
- stud bolts : A-193-B7 galvanized
- tubing : ASTM A36
- sealing gasket : SBR
- finishing : according to AWWA
- pressure class : PN10-PN16-PN25

Pieces for special conditions are available on request.

DRESSER 128 type joint

Materials

- body and flanges : ASTM A36
- screws and bolts : SAE 1020 galvanized
- sealing gasket : SBR
- finishing : according to AWWA
- pressure class : PN10-PN16-PN25

Pieces for special conditions are available on request.

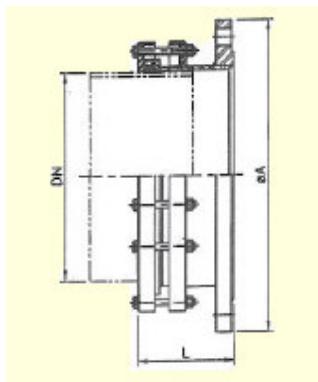

Rigid joint

Materials

- body and flanges : ASTM A36
- screws and bolts : SAE 1020 galvanizados
- sealing gasket : SBR
- finishing : according to AWWA
- pressure class : PN10-PN16-PN25

Pieces for special conditions are available on request.

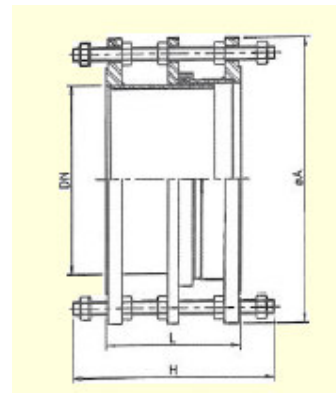

DN mm	Pipe outside Ø mm	Ø A mm	L mm	Weight Kgf
250	273	395	220	30
300	323,9	445	220	44
350	355,6	505	220	60
400	406,4	565	220	71
500	508	670	240	88
600	609,6	780	240	106
700	711,2	895	240	133
800	812,9	1015	240	189
900	914,4	1115	240	220
1000	1016	1230	260	272
1200	1219,2	1455	260	370
1400	1422,4	1675	280	468
1600	1625,6	1915	280	611
1800	1828,8	2115	280	744
2000	2032	2325	300	902
2200	2235,2	2550	300	1055
2400	2438,4	2760	320	1250
2600	2641	2960	320	1439

DN mm	Pipe outside Ø mm	Ø A mm	L mm	H mm	Weight Kgf
250	273	395	230	370	80
300	323,9	445	230	370	96
350	355,6	505	230	370	112
400	406,4	565	230	370	139
500	508	670	260	400	184
600	609,6	780	260	420	233
700	711,2	895	260	420	302
800	812,9	1015	290	480	406
900	914,4	1115	290	480	475
1000	1016	1230	290	480	564
1200	1219,2	1455	320	520	860
1400	1422,4	1675	380	580	1178
1600	1625,6	1915	380	580	1622
1800	1828,8	2115	420	640	1989
2000	2032	2325	420	640	2388
2200	2235,2	2550	460	700	3060
2400	2438,4	2760	460	700	3704
2600	2641	2960	460	700	4256